

KBPC35005W THRU KBPC3510W

High Current 35 AMPS. Single Phase Glass Passivated Bridge Rectifiers

Voltage Range 50 to 1000 Volts Current 35 Amperes

KBPC-W

FEATURES

- ◆ Ideal for printed circuit board
- ◆ Reliable low cost construction technique results in inexpensive product
- ◆ High temperature soldering guaranteed:
260°C / 10 seconds / 0.375" (9.5mm)
lead length at 5 lbs., (2.3 kg) tension
- ◆ UL Recognized File number: E347214

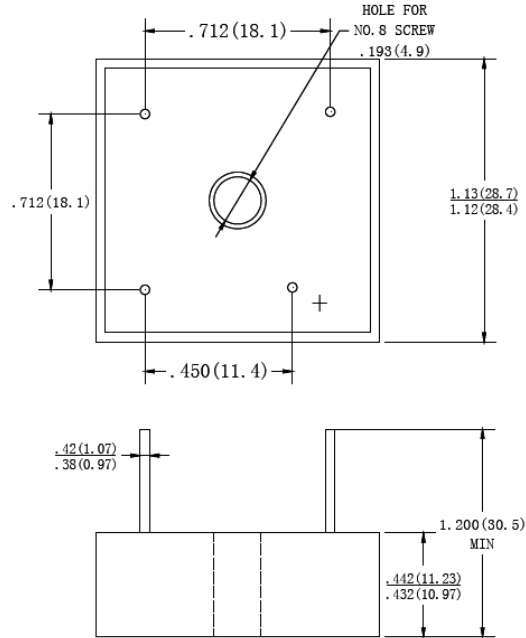

Dimensions in inches and (millimeters)

MECHANICAL DATA

- ◆ Case: Molded plastic
- ◆ Lead: solder plated
- ◆ Polarity: As marked

MAXIMUM RATINGS AND ELECTRICAL CHARACTERISTICS

Rating at 25°C ambient temperature unless otherwise specified.

Single phase, half wave, 60Hz, resistive or inductive load. For capacitive load, derate current by 20%

Type Number	SYMBOLS	KBPC 35005W	KBPC 3501W	KBPC 3502W	KBPC 3504W	KBPC 3506W	KBPC 3508W	KBPC 3510W	UNITS
Maximum Repetitive Peak Reverse Voltage	V_{RRM}	50	100	200	400	600	800	1000	V
Maximum RMS Voltage	V_{RMS}	35	70	140	280	420	560	700	V
Maximum DC Blocking Voltage	V_{DC}	50	100	200	400	600	800	1000	V
Maximum Average Forward Rectified Current at $T_c=55^\circ\text{C}$	$I_{(AV)}$	35							A
Peak Forward Surge Current, 8.3ms Single Half Sine-wave Superimposed on Rated Load (JEDEC method)	I_{FSM}	400							A
Maximum Instantaneous Forward Voltage at 17.5A	V_F	1.1							V
Maximum DC Reverse Current at Rated DC Blocking voltage per Element	I_R	10							μA
Typical Thermal Resistance (Note)	$R_{\theta JC}$	2.0							$^\circ\text{C}/\text{W}$
Operating Temperature Range	T_J	-55 to +150							$^\circ\text{C}$
Storage Temperature Range	T_{STG}	-55 to +150							$^\circ\text{C}$

Note: Thermal Resistance from Junction to Case.

KBPC35005W THRU KBPC3510W

RATING AND CHARACTERISTIC CURVES KBPC35005W THRU KBPC3510W

FIG.1- MAXIMUM NON-REPETITIVE FORWARD SURGE CURRENT PER BRIDGE ELEMENT

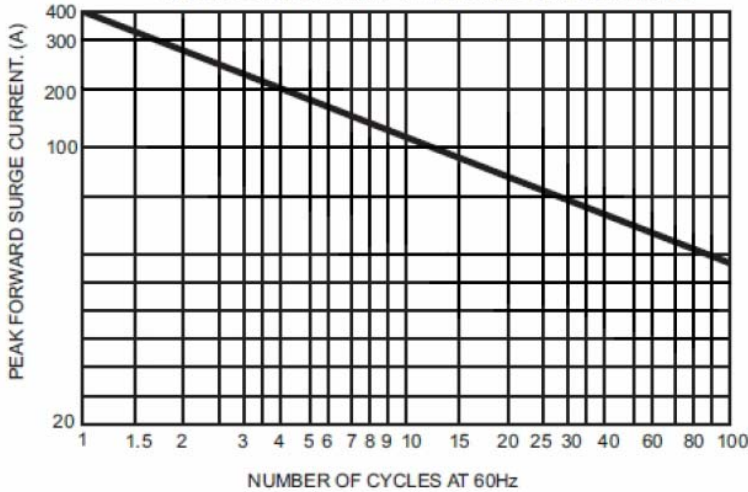

FIG.2- MAXIMUM FORWARD CURRENT DERATING CURVE

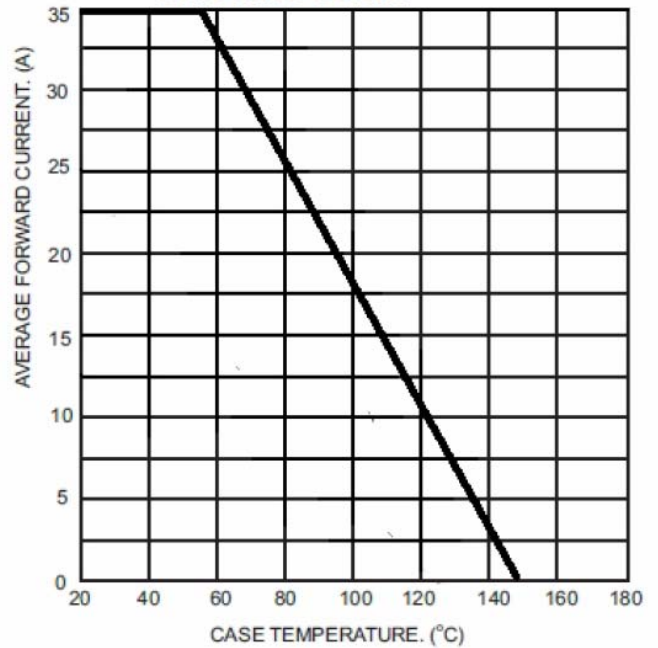

FIG.3- TYPICAL FORWARD CHARACTERISTICS PER BRIDGE ELEMENT

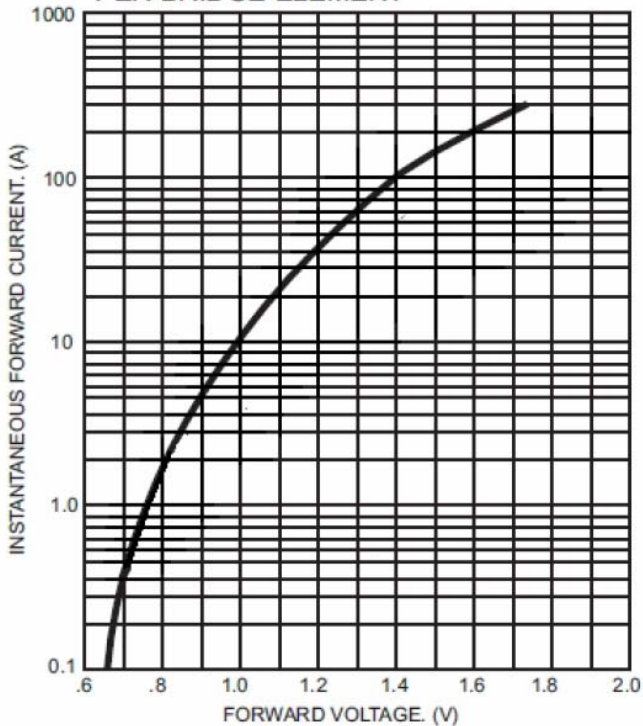

FIG.4- TYPICAL REVERSE CHARACTERISTICS PER BRIDGE ELEMENT

